



PERFORMANCE EVALUATION OF AN STBC ENCODED MIMO-OFDM SYSTEM UNDER IMPLEMENTATION OF SVD BASED CHANNEL ESTIMATION TECHNIQUE

¹Aurangzib Md Abdur Rahman, ²Most. Hasna Hena,

¹Associate Prof, ²Lecturer,

¹Department of Information and Communication Engineering, ²Department of Computer Science and Engineering,

¹University of Rajshahi, ²Daffodil International University,

¹Rajshahi 6205, Bangladesh, ²Dhaka 1207, Bangladesh.

Abstract:-

This paper incorporates a comprehensive BER simulation study undertaken on the effectiveness of a space time block encoded multiple-input multiple-output orthogonal frequency division multiplexing (MIMO-OFDM) communication system under implementation of $\frac{1}{2}$ -rated convolutionally encoding scheme. The MIMO-OFDM system under present study has incorporated four digital modulations (BPSK, DPSK, QPSK and QAM) over AWGN and Rayleigh fading channel for two transmit and two receive antennas. It implements Singular value decomposition (SVD) based channel equalization algorithm. Computer simulation tests have been conducted with synthetically generated binary data and the results on Bit error rate (BER) demonstrate that the MIMO-OFDM system with QAM modulation technique is highly effective to combat inherent interferences under Rayleigh fading and AWGN channels. It is anticipated from the simulation study that the retrieving performance of the MIMO-OFDM communication system degrades with the lowering of the signal to noise ratio (SNR).

Keywords: - STBC, MIMO-OFDM, FEC encoding, SVD channel estimation, AWGN and Rayleigh Fading channels.

1. INTRODUCTION

Modern mobile communication systems adopt the digital modulation scheme instead of previously used analog modulation. Digital modulation is very much advantageous in noise immunity and robustness to channel impairments [1]. Initial field tests of broadband wireless MIMO-OFDM communication systems have shown that an increased capacity, coverage and reliability are achievable with the aid of MIMO techniques. Furthermore, although MIMO's can potentially be combined with any modulation or multiple-access technique, recent research suggests that the implementation of MIMO-aided OFDM is more efficient, as

Corresponding author: Aurangzib Md Abdur Rahman,

Email: wazihtaosif@yahoo.com

a benefit of the straightforward matrix algebra invoked for processing the MIMO-

OFDM signals . In recent years, this topic has attracted substantial research efforts, addressing numerous aspects, such as system capacity, space/time/frequency coding, Peak-to-Average Power Ratio (PAPR) control, channel estimation, receiver design etc [2]. Low-bit cost is an essential requirement in a scenario where high volumes of data are being transmitted over the mobile network. According to cost per bit should be between 1/10 and 1/100 of 3G systems [3]. Space- Time Block Coding can realize the spatial diversity of a narrow band wireless communication system where the channel is assumed to be flat fading. It can be extended to a wide band frequency selective channel by combining the space time block coding and OFDM. Compared with WF-OFDM, STBC OFDM has a much simpler transceiver structure as well as a lower computation complexity. There are two ways to combine STBC into OFDM, in frequency domain or in time domain. The way we take here is to employ the space-time block codes as space-frequency block codes (by coding across space and frequency) [4]. Tarokh, V et. al [5], [6] has reported about STBC-OFDM system and other people also has done their research in this field but still it has more interest. From those points of view, we have made a comprehensive study on the performance evaluation of a MIMO OFDM wireless communication system utilizing Alamouti encoding space time block coding scheme.

2. MIMO-OFDM SYSTEMS

Figure 1 shows the basic model of MIMO-OFDM system with M and N number of antenna at the transmitter and receiver, respectively. In this model MIMO transmission is assumed to be OSTBC (Orthogonal Space-Time Block Coded). Therefore the block of user information after mapping in MPSK modulator is coded by the MIMO-STBC encoder with the matrix dimension of $P \times M$ and code rate of P/M [7]. Where P is the number of time interval

needed to transmit this matrix by M number of transmit antenna. It should be mentioned here that every elements of this coded matrix is an OFDM block with 64 symbols.

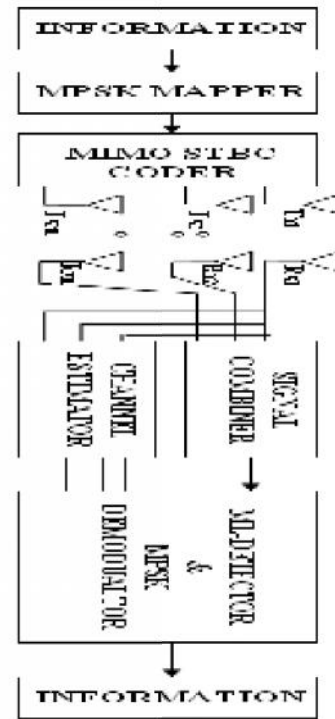

Figure 1. Schematic of a MIMO-OFDM system model.

Every columns of this matrix before transmission is fed to M number OFDM module. In this module before adding cyclic prefix (CP) IFFT transformation is performed for each elements of the encoded matrix. If the columns of encoded matrix which enter to the OFDM block is $(X^1, X^2, \dots, X^m)^T$ in frequency domain then the output of OFDM module will be $(x^1, x^2, \dots, x^m)^T$ in time domain.

Each elements of encoded matrix X^k before OFDM module has a length of $N= 64$ symbols while after OFDM module change to x^k in time domain with the length of 80 symbols. The received signal after distortion by frequency selective channel and AWG noise at antenna j from antenna i can be represented by the following equation -

$$y^j(n) = \sum_{i=1}^M \sum_{l=0}^{L-1} h_l^{ji}(n) \cdot x^i(l-n) + v^j(n)$$

Where $h_l^{ji}(n)$ is l th channel coefficient between received antenna j and transmitted antenna i at time n . $v^j(n)$ is AWGN with zero mean and variance one.

3. SYSTEM MODEL AND DESCRIPTION

A simulated MIMO-OFDM wireless communication system depicted in Figure 2 utilizes 1/2-rated Convolutional channel coding and space time block coding schemes. In such a communication system, two transmit antennas and two receive antennas and 1024-tone OFDM are used.

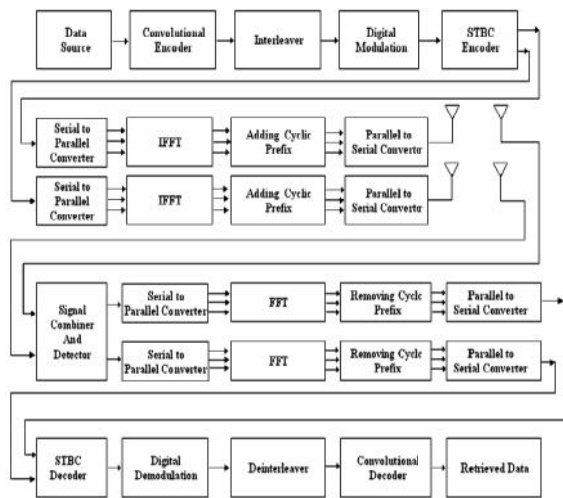

Figure 2. Block diagram of Alamouti encoded model for multi-user DS-CDMA system

The transmitted bit of a single user is channel encoded and interleaved for minimization of burst errors. The interleaved bits are digitally modulated and fed into Space time block code (STBC) encoder. In STBC coding section, the digitally modulated complex symbols are spatially demultiplexed into two sub streams and fed into two OFDM modulating channels.

In each OFDM transmitting channel with 1024 subcarriers, the STBC encoded symbolic data streams are first passed through OFDM modulator which performs an IFFT on blocks of length 1024 followed by a parallel to serial conversion. A cyclic prefix(CP) of length L_{cp} ($0.1 \cdot 1024$) containing a copy of the last L_{cp} samples of the parallel to serial converted output of the 1024-point IFFT is then pretended. The resulting OFDM symbols of length $1024 + L_{cp}$ are lunched simultaneously from the individual transmit antenna. In the receiver the transmitted signals contaminated with AWGN and fading channel effects are processed with Singular value decomposition based channel equalization technique to decode the signals transmitted. The signals are passed through serial to parallel converter and with discarding of the CP and a 1024-point FFT is performed in OFDM demodulator. The output of the OFDM demodulator are sent up into parallel to serial to converter and fed into STBC decoder. The output of the STBC decoder is sent into digital de-mapping section. The demodulated signals are de-interleaved and fed into Convolutional decoder and the output of the channel decoder provides the retrieved data for the user.

4. RESULTS AND DISCUSSIONS

Simulation parameters for the proposed system model are shown in Table 1. Computer simulations have been conducted using programs written in Matlab 10 with a view to evaluating the BER performance of a 2 x 2 spatially multiplexed Convolutionally encoded MIMO OFDM wireless communication system. It is assumed that the channel state information (CSI) is available at the receiver and the fading process is approximately constant during each time slot assigned for

simultaneous transmission of OFDM symbols from two transmitting antennas.

Parameters	Values
No. of bits used	1024/2048
Antenna configuration	2-by-2
OFDM Block Size	1024 symbols
CP Length	102 symbols
Channel Coding /Decoding	1/2-rated Convolutional coding/ decoding
Modulation	BPSK, DPSK, QPSK and QAM
Signal Detection Scheme	Maximum-Likelihood
Channel	AWGN and Rayleigh
Signal to noise ratio, SNR	0 to 10 dB

Table 1. Parameters used for simulation of the proposed model

The present study focuses the impact of deployment of 1/2-rated Convolutional encoding/decoding schemes on the STBC diversity encoded MIMO OFDM wireless communication system. The results are compared between different modulation techniques. In this present simulation based study, it is being considered that a single user is sending his/her synthetically generated binary data or text message through such FEC encoded MIMO-OFDM system.

Figure 3 shows the STBC based MIMO-OFDM system performance comparison without implementation of Channel encoding scheme in AWGN channel. It is clear from Figure 3 that the system outperforms in QAM while shows worst performance in DPSK digital modulation. The BER performance difference is quite obvious in lower SNR areas and the system's BER declines with increase in SNR values. From Figure 3, it is noticeable under

channel un-coded situation that for a typically assumed SNR value of 3 dB, the BER values are 0.025 and 0.230 in case of QAM and DPSK digital modulations, respectively, which indicates that the system achieves a substantial gain of 9.64 dB in QAM as compared to DPSK. The estimated BER values at different SNRs ranging from 1.0 to 10.0 dB for such channel un-coded wireless communication system.

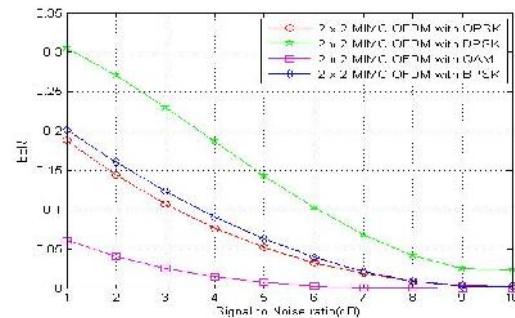

Figure 3. BER Performance for un-coded MIMO-OFDM based wireless communication system with implementation of SVD channel estimation scheme under different digital modulations in AWGN channel.

Figure 4 shows the STBC based MIMO-OFDM system performance comparison with implementation of Channel encoding scheme under Rayleigh channel. Figure 4 also shows that the system performance enhances in the case of using QAM while shows the worst performance in DPSK digital modulation. So, it can be noted that in MIMO-OFDM communication system, QAM would be a preferable modulation technique. For FEC encoded MIMO-OFDM based wireless communication system with implementation of SVD channel estimation scheme under different digital modulations, BER performance shows that for a typically assumed value of SNR 3dB the BER values are 0.014 and 0.463 in the case of QAM and DPSK, respectively, which is indicative of an enhancement of system performance by 15.19 dB.

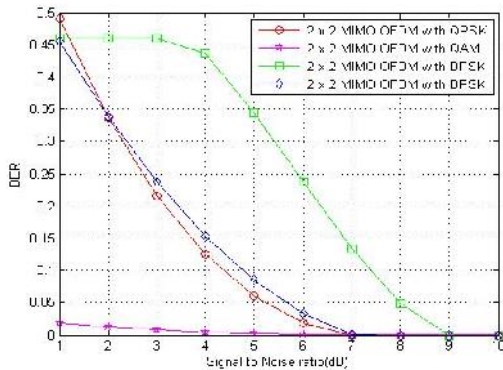

Figure 4. BER Performance for FEC encoded MIMO-OFDM based wireless communication system with implementation of SVD channel estimation scheme under different digital modulations in Rayleigh channel.

The performance of an STBC based MIMO-OFDM communication system for text message under channel encoding scheme in Rayleigh channel is shown in Figure 5. In this case also QAM shows the best performance but DPSK shows the worst performance. The BER performance difference is quite noticeable in lower SNR areas and the system's BER declines with increase in SNR values.

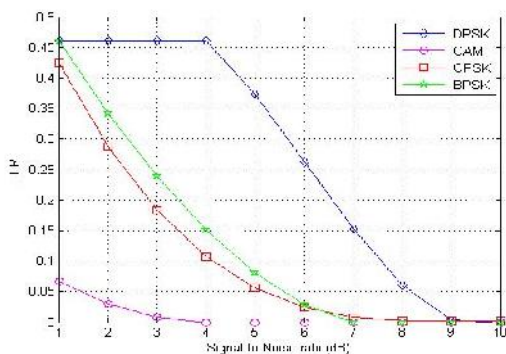

Figure 5. BER Performance for FEC encoded MIMO-OFDM based wireless communication system for text data with implementation of SVD channel estimation scheme under different digital modulations in Rayleigh channel.

Finally, the transmitted and retrieved binary bits for a typical SNR value of 1 dB under QAM digital modulation is shown in Figure 6 (a). In this case, estimated value of bit error rate is 0.064. The transmitted and retrieved binary bits for a typical SNR value of 4dB under QAM digital modulation is shown in Figure 6 (b). Here estimated value of bit error rate is 0.000 which means that the transmitted information was completely recovered without any error.

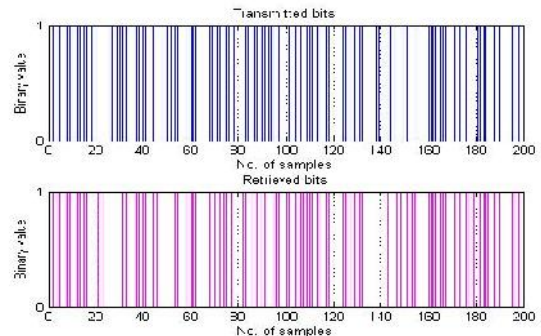

Figure 6 (a). A segment of transmitted and retrieved bits for a typical SNR value of 1 dB.

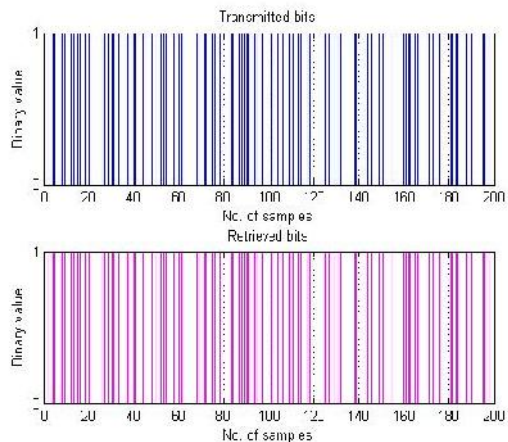

Figure 6 (b). A segment of transmitted and retrieved bits for a typical SNR value of 4 dB.

CONCLUSION

In this research work, we have presented simulation results concerning the adaptation of Singular value decomposition (SVD) based channel estimation algorithm in a Convolutionally encoded STBC

implementation based MIMO-OFDM wireless communication system. A range of system performance results highlights the impact of Convolutionally encoding/decoding and STBC schemes on synthetically generated bit stream. In the context of system performance, it can be concluded that the implementation of QAM digital modulation technique in SVD channel estimation technique provides satisfactory result for such a MIMO-OFDM wireless communication system.

REFERENCES

- [1]Pashtan, Ariel,” **Wireless Terrestrial Communications**”, Cellular. Telephony. Aware Networks, Inc. **Buffalo Grove, Illinois, USA**, 2006.
- [2]L. Hanzo, J. Akhtman, L. Wang, M. Jiang, “MIMO-OFDM for LTE,WiFi, and WiMAX : coherent versus non-coherentand cooperative turbo-transceivers” John Wiley & Sons Ltd, United Kingdom, 2011.
- [3]Vasco Pereira and Tiago Sousa, “Evolution of Mobile Communications”, Department of Informatics Engineering, University of Coimbra, West Yorkshire, United kingdom.
- [4]Rouquette-Leveil, S.; Gosse, K.; Xiangyang Zhuang; Vook, F.W.,”Spatial Division Multiplexing of Space-time Block Codes”, ICCT Proceedings, April 2003, Pages:1343 – 1347.
- [5] Tarokh, V., Jafarkhani, H. and Calderbank, A.R., “Space-time block codes from Orthogonal designs”. IEEE Trans.on Information Theory, 45(5):July1999, 1456–67.
- [6] Tarokh, V., Jafarkhani, H., and Calderbank, A. R., “Space-time Codes for High Data Rate Wireless Communication: Performance Criterion and Code Construction,” IEEE Trans. Inform. Theory, Vol. 44, No. 2, pp. 744-765, July 1998.

- [7] G. Raleigh and J. M. Cioffi, “Spatio-temporal coding for wireless communications,” IEEE Transactions on Communications, vol. 46, no. 3, pp. 357-366, Mar. 1998.